

Description

Moore Industries' DIN-style DDA Direct Current Alarm accepts all standard process current and voltage inputs from field transmitters and transducers. When the input value falls outside of a fully-adjustable preset limit, the DDA provides an alarm (contact closure) output ideal for indicating a high and/or low condition via a bell, buzzer, light or other device.

The DDA is offered in both single and dual alarm models. The dual alarm models allow configuration of two separate trip points per module (High/Low, High/High, or Low/Low).

Trip point settings are configured via front panel potentiometers. To simplify this procedure, the upper and/or lower setting(s), as well as the input signal, can be displayed on a front panel indicator. High/Low selection is made with internal solderless jumpers. Bright LEDs, also located on the front panel, indicate when the unit is in an alarm condition (LED "ON" indicates relay is energized).

The DDA is offered with a variety of options including 2-wire transmitter excitation, adjustable deadband, and display of engineering units on the integral indicator. For a complete listing of available options, see the back page.

Ordering Information

To order, use the bold face data from the Ordering Specifications section of the Specification Table on the back page. For assistance, refer to the model number example presented at the bottom of the table.

Figure 1. Normal Failsafe High and Low Alarm Configuration.

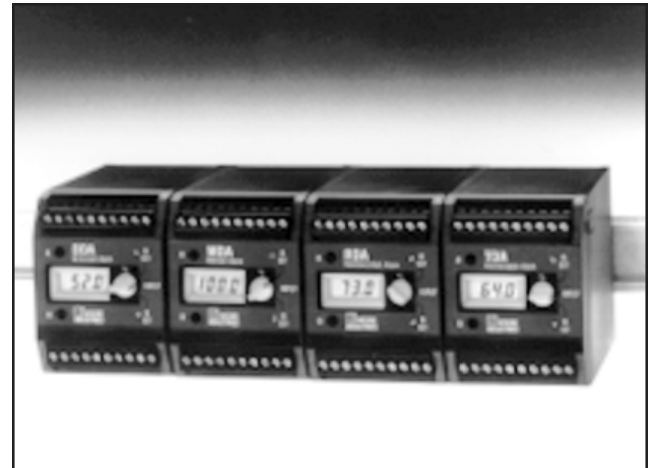
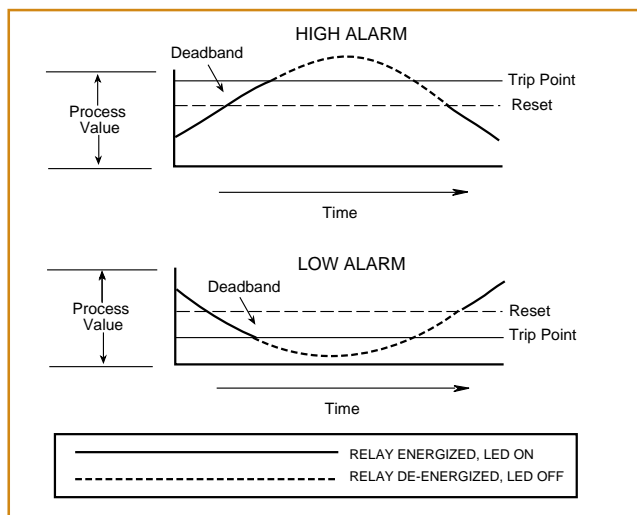

The DDA DIN-style rail-mount alarm is ideal for high-density mounting in a control room or in a field-mounted enclosure.

Features

- **Integral indicator.** Trip point settings can be displayed on the integral display which greatly simplifies trip point configuration.
- **On-site monitoring of input.** The indicator displays the input value in percentage (standard) or in engineering units (-EU option).
- **Wide range of inputs and outputs.** Accepts all standard current and voltage inputs from almost any temperature, pressure, level, or flow transmitters as well as other current and voltage sources.
- **RFI/EMI protection/complete isolation.** Complete input/output/power isolation and inherent RFI/EMI protection prevents false alarms from occurring in "noisy" environments.



Canadian Standards Association (CSA)
General (Ordinary) Location – DIN housing



CE Conformant – EMC Directive 89/336/EEC
EN 50081-2, 1993 and EN 50082-2, 1995.

DDA

DIN-Style Current and Voltage Alarm

Specifications

<p>Performance</p> <p>Display Accuracy: ±0.1% of input span; ±1 count to include repeatability, hysteresis, and adjustment resolution</p> <p>Repeatability: Trip point repeats within ±0.1% of input span</p> <p>Dead Band: 1% of input span (standard)</p> <p>Signal Response: -3dB @ 5Hz typical (low pass)</p> <p>Alarm Response: 50 milliseconds standard (input signal must be beyond trip point continuously for 50 milliseconds before an alarm state is output)</p> <p>Isolation: 500Vac, input to output to power</p>	<p>Performance (continued)</p> <p>RF/EMI Effect: With field strengths of 10V/m, at frequencies of 20-500Mhz, unit will not go into alarm status unless process variable is within ±1.0% of trip point</p> <p>Ambient Temperature Range: -18°C to +65°C (0°F to +150°F)</p> <p>Effect: ±0.018%/°C (±0.01%/°F) over above range</p> <p>Adjustments</p> <p>Front Panel Adjustments</p> <p>Type: Multiturn potentiometers</p> <p>Trip Point(s): Adjust over a range of -5% to 105% of span, typical</p> <p>Input/Trip Point Viewing: Two- or three-position rotary switch allows selection of viewing the Input, Trip A or Trip B on the integral LCD</p>	<p>Adjustments (continued)</p> <p>Internal Adjustments</p> <p>Type: Multiturn potentiometers</p> <p>Zero: Adjustable to ±10% of span</p> <p>Span: With full scale input, output is adjustable to 100%, ±10%</p> <p>Indicators</p> <p>Display: 3-1/2 digit LCD displays either Input, Trip A or Trip B as determined by rotary switch; display indicates from -5.0% to 105% of input span and is linear with respect to the input signal</p> <p>Trip Point: LED(s) on front panel indicates alarm status for each trip point ("ON" LED indicates energized relay)</p> <p>Weight 297 grams (10.5 ounces)</p>
---	--	---

Ordering Specifications

Unit	Input	Output	Power	Options	Housing
DDA	<p>Current:</p> <p>0-20MA @ 25 ohms</p> <p>1-5MA @ 100 ohms</p> <p>4-20MA @ 25 ohms</p> <p>10-50MA @ 10 ohms</p> <p>Voltage (@ 1 megohm):</p> <p>0-1V</p> <p>0-5V</p> <p>1-5V</p> <p>0-10V</p>	<p>Alarm Configuration: (High/Low and Failsafe/Non-Failsafe are jumper-selectable)</p> <p>SH1 Single, High, Failsafe</p> <p>SH2 Single, High, Non-Failsafe</p> <p>SL1 Single, Low, Failsafe</p> <p>SL2 Single, Low, Non-Failsafe</p> <p>DH1L1 Dual, high/low, failsafe</p> <p>DH2L2 Dual, high/low, non-failsafe</p> <p>DH1H1 Dual, high/high, failsafe</p> <p>DH2H2 Dual, high/high, non-failsafe</p> <p>DL1L1 Dual, low/low, failsafe</p> <p>DL2L2 Dual, low/low, non-failsafe</p> <p>(DPDT relays standard on single alarms, SPDT relays standard on dual alarms; relay contacts rated 5A @ 117Vac or 28Vdc or 2A @ 240Vac; all non-inductive loads, 50/60Hz)</p>	<p>24DC</p> <p>Accepts 24Vdc, ±10% (1.5 to 2.5 watts nominal)</p>	<p>-AD Adjustable deadband, 1-20%, nominal (available up to 100%)</p> <p>-AR Alarm response time delay; specify between 1-30 seconds (factory set)</p> <p>-DPSTNO DPST normally open relays (dual alarms)</p> <p>-DPSTNC DPST normally closed relays (dual alarms)</p> <p>-DPSTNONC DPST with one normally open and one normally closed contact per relay (dual alarms)</p> <p>-EU Indicator displays in engineering units (0-200 through 0-1999); For engineering unit values not starting at zero, consult factory</p> <p>-GR Adaptor for mounting on a DIN (50035-G32) G-rail</p> <p>-HS Hermetically sealed relays rated at 3A @ 28Vdc non-inductive or 1A @ 120Vac non-inductive, 50/60Hz</p> <p>-MR Manual reset terminals provided; pushbuttons must be supplied by user</p> <p>-TX 2-wire transmitter excitation, 24Vdc nominal @ 25mA</p>	<p>DIN</p> <p>Thermoplastic, DIN-style rail mount housing with removable terminal blocks (35mm Top Hat Rail)</p>

When ordering, specify: Unit / Input / Output / Power / Options [Housing]

Model number example: DDA / 4-20MA / SH1 / 24DC / -AD -GR -TX [DIN]

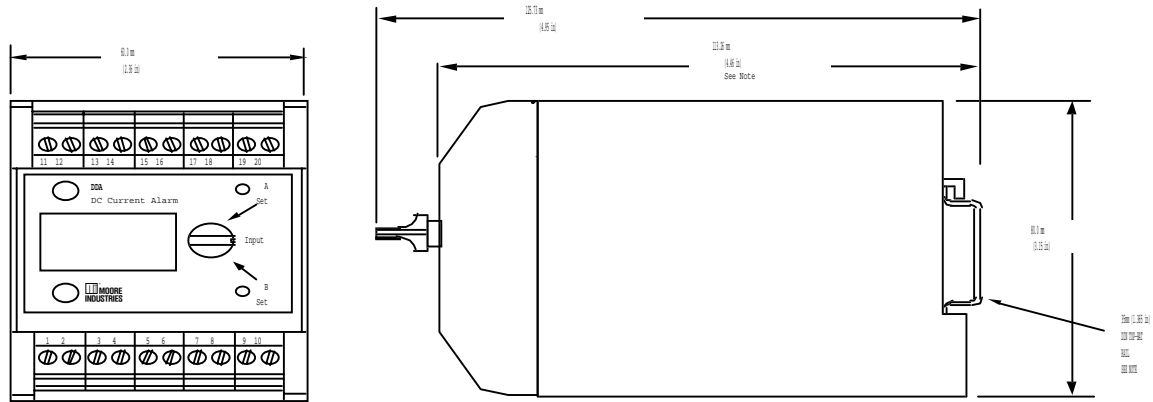

NOTE

1. Add 16.76mm (.66 in.) to dimensional length for -GR option.

Figure 2. Outline and Installation Dimensions

Table 1. Four-Wire DIN-Style Alarm Terminal Designations

Unit	1	2	3	4	5, 6	7, 8*	9, 10*	11	12	13	14	15	16	17	18	19	20
DDA SINGLE/DPDT	+IN	-IN	NOT USED	+TX	NOT USED		MR	DC	DCC	NO1	CM1	NC1	NO2	CM2	NC2		
SINGLE/SWITCHOUT	+IN	-IN		+TX			MR	DC	DCC	+TSO	-TSO						
DUAL/SPDT	+IN	-IN	NOT USED	+TX	NOT USED	BMR	AMR	DC	DCC	ANO	ACM	ANC	BNO	BCM	BNC		
DUAL/SWITCHOUT	+IN	-IN		+TX		BMR	AMR	DC	DCC	+ATSO	-ATSO			+BTSO	-BTSO		
DUAL/DPST/NO	+IN	-IN		+TX		BMR	AMR	DC	DCC	ANO1	ACM1	ANO2	ACM2	BNO1	BCM1	BNO2	BCM2
DUAL/DPST/NC	+IN	-IN		+TX		BMR	AMR	DC	DCC	ANC1	ACM1	ANC2	ACM2	BNC1	BCM1	BNC2	BCM2
DUAL/DPST/NONC	+IN	-IN		+TX		BMR	AMR	DC	DCC	ANO1	ACM1	ANC2	ACM2	BNO1	BCM1	BNC2	BCM2

Table 2. Key To Abbreviations

Abbreviation	Description
1 (suffix)	Contact set 1
2 (suffix)	Contact set 2
A (prefix)	Relay 1, dual alarm
B (prefix)	Relay 2, dual alarm
CM	Common
IN	Input signal
MR	Manual reset
NC	Relay contact, normally closed
NO	Relay contact, normally open
DC	+DC power input
DCC	-DC power input
TSO	Transistor switch output
-TX	Transmitter power supply